

1st stage a-108

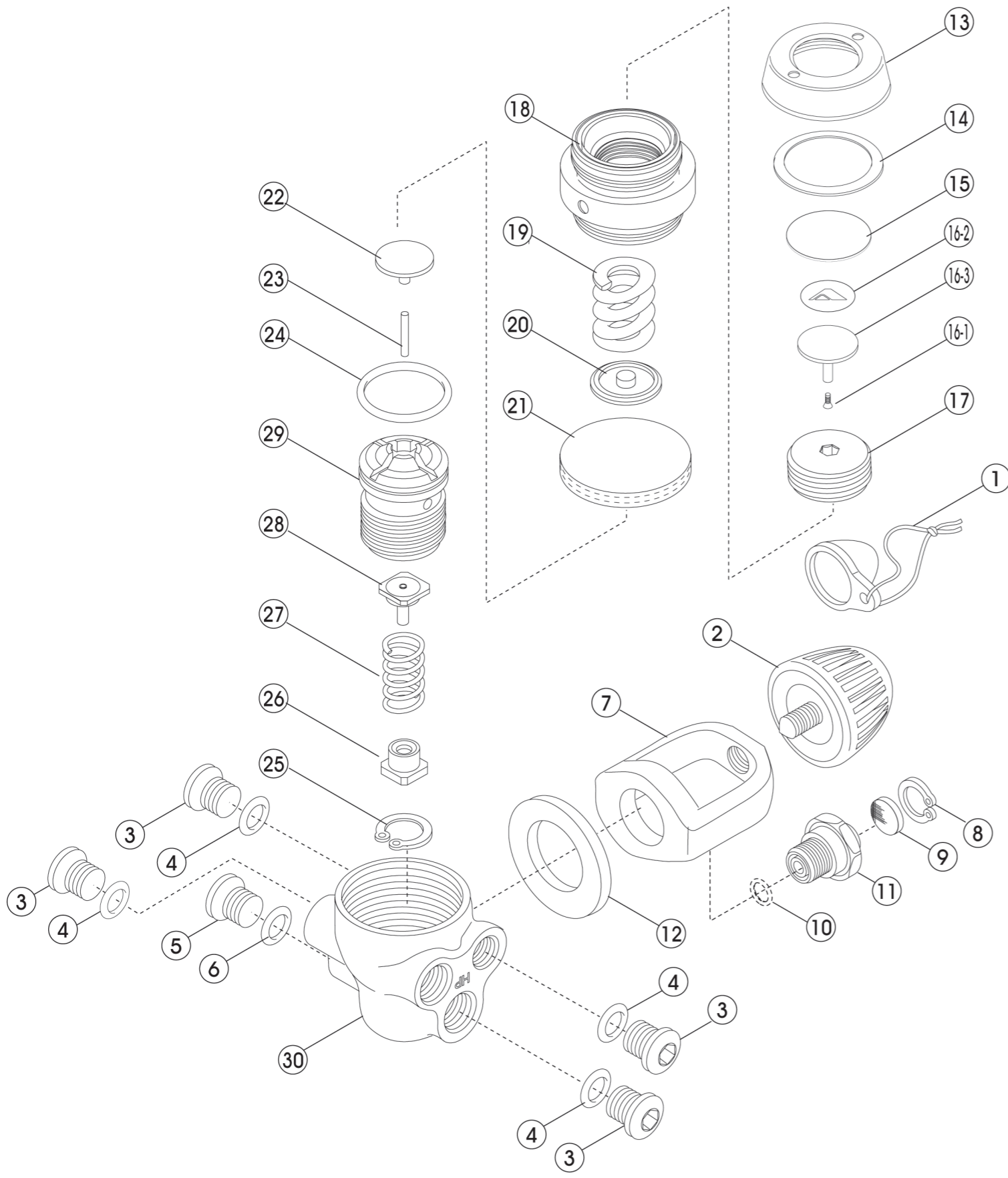

No.	Code	Description	Note
1	1184380003	DUST CAP ASSY	
1-1	3104080280	STRING FOR DUST CAP	
1-2	3103080010	DUST CAP FOR YOKE	
2	2102080158	YOKE SCREW WITH DECAL	
2-1	3104680004	YOKE DECAL (BK) Not Sale	
2-2	3102080158	●YOKE SCREW change to 2102080158	OUT OF PRODUCTION
3	3100101101	PLUG (A) : 3/8 FOR L.P.	
4	3993592011	O-RING ARP-011/HS75	
5	3100101102	PLUG (C) : 7/16 FOR H.P.	
6	3993592012	O-RING ARP-012/HS75	
7	3101300031	YOKE : A-320	
8	3990500101	RETAINING RING	
9	3990800411	FILTER 150 MICRON :SUS316 D/12.6 T/1.66	
10	3993592011	O-RING ARP-011/HS75	
11	3100101106	YOKE RETAINER : A-102/108/320	
12	3102480000	YOKE SPACER : A-108/320	
13	3100101107	OUTER DIAPHRAGM HOLDER : FOR A-108	
14	3102480001	DIAPHRAGM WASHER PET	
15	3102400021	OUTER DIAPHRAGM	
16-1	3990100079	SCREW M2X8	
16-2	3104681000	BIO MARKED STICKER FOR PISTON	
16-3	3100101108	PISTON : FOR A-108/110/320	
17	3100101110	ADJUST SCREW : FOR A-108/110/320	
18	3100101109	LOCK NUT : FOR A-108	
19	3101200062	ADJUST SPRING FOR L.P.:FOR REGULATOR	
20	3100101111	SPRING PAD : FOR A-101,2,5,7,8,10,320	
21	3103980105	HIGH PRESSURE DIAPHRAGM	
22	3100101105	PUSH ROD PAD : FOR A-101,2,5,7,8,10	
23	3990100072	PUSH ROD PIN : A-101,2,5,7,8,10 (SUS304)	
24	3993594017	O-RING ARP-017/HS90	
25	3990500101	RETAINING RING	
26	2100100050	BALANCE CHAMBER WITH O-RING: A-101,2,5,7,8,10,20	
26-1	3993592006	O-RING ARP-006/HS75	
26-2	3102070000	BACKUP RING: A-101,2,5,7,8,10,320	
26-3	3100101103	BALANCE CHAMBER : FOR A-101,2,5,7,8,10	
27	3101200071	HIGH PRESSURE SPRING : A-101,2,5,7,8,10,320	
28	3100103210	PTMEG 2000 HIGH PRESSURE SEAT	
29	3100101115	H.P. MODULE WITH GUIDE SPEC FOR REGULATOR	
30	3101300000	BODY : A-108	OUT OF PRODUCTION