

# 1st stage a-230 Nrx

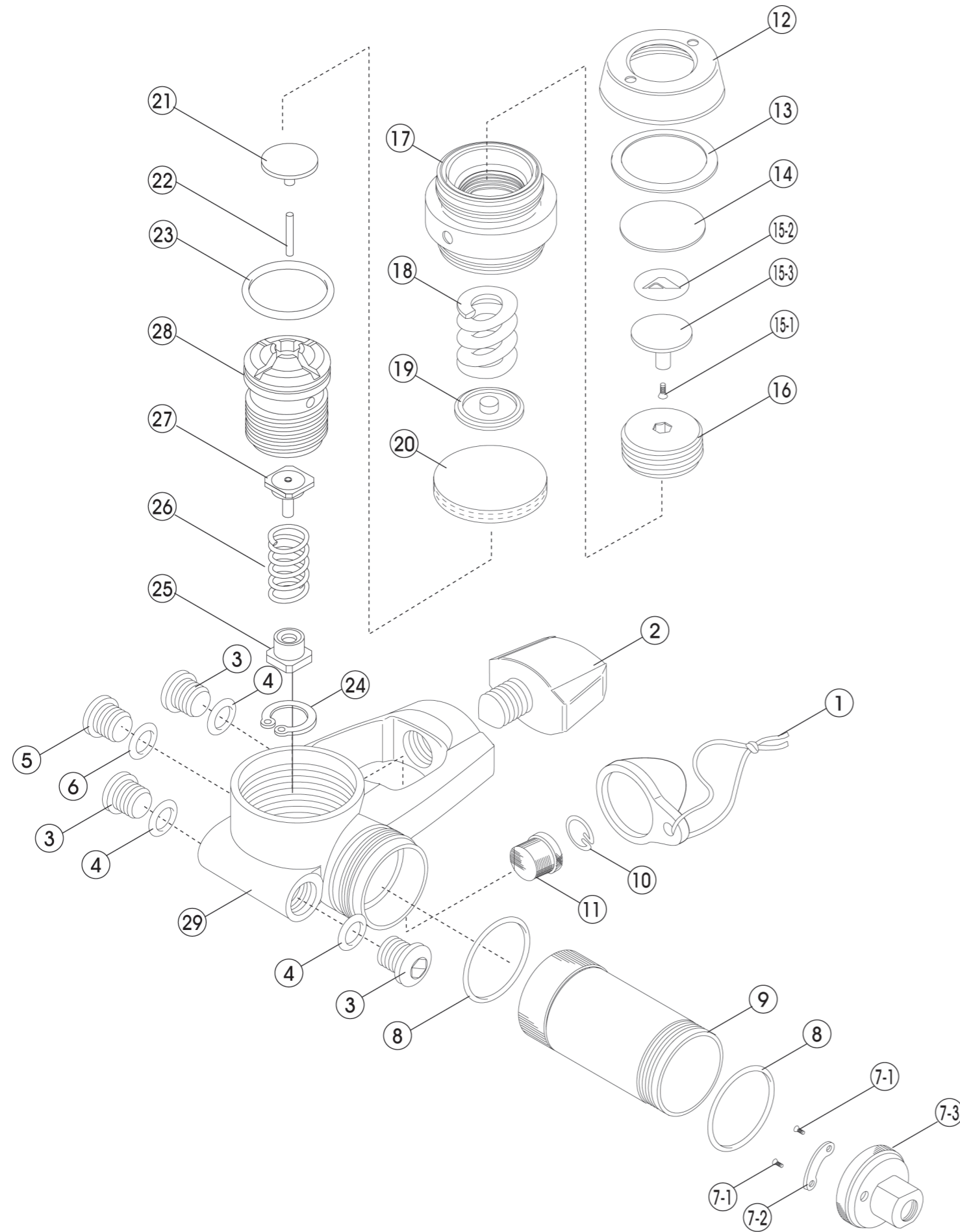

No.	Code	Description	Note
1	2184380001	DUST CAP FOR YOKE WITH STRING	
1-1	3104080280	STRING FOR DUST CAP	
1-2	3103080010	DUST CAP FOR YOKE	
2	2122080000	● YOKE SCREW	OUT OF PRODUCTION
3	3100101101	PLUG (A) : 3/8 FOR L.P.	
4	3993898011	O-RING ARP-011/HS90 VITON ID/7.65	
5	3100101102	PLUG (C) : 7/16 FOR H.P.	
6	3993898012	O-RING ARP-012/HS90 VITON ID/9.25	
7	2120270101	MOISTURE CAP WITH WATER FILLING PORT : A-230	
7-1	3120010001	SCREW FOR CHECK VALVE BIO FILTER BS	
7-2	3122000101	CHECK VALVE FOR BIO FILTER (BK)	
7-3	3121300021	MOISTURE CAP WITH WATER FILLING PORT 3/8 BS	
8	3993592023	O-RING ARP-023/HS75	
9	3121300022	HUMIDIFY TUBE : A-230	
10	3101200064	FILTER RETAINER FOR A-102,108,110,120	
11	3990800412	FILTER 150 MICRON BUCKET TYPE	
12	3100101107	OUTER DIAPHRAGM HOLDER : FOR A-108	
13	3102480001	DIAPHRAGM WASHER PET	
14	3102400021	OUTER DIAPHRAGM	
15-1	3990100079	SCREW M2X8	
15-2	3104681000	BIO MARKED STICKER FOR PISTON	
15-3	3100101108	PISTON : FOR A-108/110/320	
16	3100101110	ADJUST SCREW : FOR A-108/110/320	
17	3100101109	LOCK NUT : FOR A-108	
18	3101200062	ADJUST SPRING FOR L.P.:FOR REGULATOR	
19	3100101111	SPRING PAD : FOR A-101,2,5,7,8,10,320	
20	3103980105	HIGH PRESSURE DIAPHRAGM	
21	3100101105	PUSH ROD PAD : FOR A-101,2,5,7,8,10	
22	3990100072	PUSH ROD PIN : A-101,2,5,7,8,10 (SUS304 )	
23	3993898017	O-RING ARP-017/HS90 VITON ID/17.17	
24	3990500101	RETAINING RING	
25	2100100050	BALANCE CHAMBER WITH O-RING: A-101,2,5,7,8,10,20	
25-1	3993898006	O-RING ARP-006/HS90 VITON ID/2.90	
25-2	3102070000	BACKUP RING: A-101,2,5,7,8,10,320	
25-3	3100101103	BALANCE CHAMBER : FOR A-101,2,5,7,8,10	
26	3101200071	HIGH PRESSURE SPRING : A-101,2,5,7,8,10,320	
27	3100103210	PTMEG 2000 HIGH PRESSURE SEAT	
28	3100101115	H.P. MODULE WITH GUIDE SPEC FOR REGULATOR	
29	3121300006	BODY A-230	OUT OF PRODUCTION